

# Crawler Excavator

## R 976

Litronic®



### Engine

400 kW/544 HP

Stage IV

### Operating Weight

Backhoe: 85,800 – 96,300 kg

Shovel: 91,500 – 93,300 kg

### Bucket Capacity

Backhoe: 1,50 – 6.60 m<sup>3</sup>

Shovel: 5.10 – 6.00 m<sup>3</sup>

# LIEBHERR

## Performance

Power, versatility  
and productivity

## Economy

Profitability – efficiency and  
reduced operating costs

### Engine

400 kW/544 HP

Stage IV

### Operating Weight

Backhoe: 85,800 – 96,300 kg

Shovel: 91,500 – 93,300 kg

### Bucket Capacity

Backhoe: 1.50 – 6.60 m<sup>3</sup>

Shovel: 5.10 – 6.00 m<sup>3</sup>



## Reliability

World-renowned  
robustness

## Comfort

Spacious cab, ergonomic  
and high-visibility

## Easy Maintenance

Simple and safe service  
check points



# Performance



**Power, Versatility  
and Productivity**

### High Performance for Maximum Productivity

The R 976 crawler excavator is characterised by its maximum productivity. Whether it be in earthmoving or quarry applications, this 90 tonne class excavator has an optimised hydraulic system matched together with intelligent operating modes. This ensures the capability for operating on large construction sites and quarries.

### Reliable Working Capacity

The Liebherr V8 engine on the R 976 is very productive thanks to its high torque even at low speeds. The digging and breakout forces of 390 kN and 485 kN respectively ensure fast and efficient working cycles. Equipped with a Liebherr bucket and tooth system it guarantees easy penetration into material for easy extraction. The R 976 stability and smooth movements of the machine ensure comfortable and fast loading of dump trucks.

### Optimisation of Hydraulic System for Constant Power

With an independent 3rd pump dedicated for swing the R 976 has optimal power. This provides maximum torque while swinging and the remaining two pumps still have full power for excavating and loading.

### The Versatility of the Wide Range of Attachments

Thanks to the wide variety of attachments with optimised kinematics, the R 976 impresses with its versatility in all applications.

#### Liebherr Engine

- Compliant with Stage IV emission standard with SCR exhaust gas after-treatment system
- Designed specifically for construction applications
- Liebherr Common-Rail injection system for optimised output
- Automatic fuel-saving idling system

#### Choice of Work Mode

- E Mode – Economy: for economical and ecologically-friendly operation. Minor restriction of power without affecting the load lifting and excavating capacities
- P Mode – Power: for high excavation capacities and difficult applications. Pump flow and power are not limited
- S Mode – Sensitivity: for precision jobs and loading of materials
- P+ Mode – Full Power: especially designed for increased power; only recommended for extreme applications

#### Floating Boom Function

- Increased hydraulic flow for the other cylinders (stick and/or bucket for example)
- More power available, making it easier to extract materials and reduce working cycle times
- Increased service life when a hydraulic hammer is used



# Economy



**Profitability – Efficiency and  
Reduced Operating Costs**

### Low Operating Costs

Thanks to its high technology and innovation, the Liebherr France Company increases the performance of its machines while reducing their fuel consumption. Examples of this are the new diesel engine, automatic idling, electronic engine speed sensing control, Regeneration Plus function and the hydrostatic cooling system (fans operate only when necessary). Consequently, the reduced fuel consumption means less pollution.

### LiDAT Fleet and Machine Fleet Management Tool

To improve your machine management, Liebherr has developed its own data transmission system using the GPRS network. This system allows you to instantly know the position of your excavator via a web interface. Thanks to data transmission, the LiDAT system developed and manufactured by Liebherr keeps you informed about fuel consumption, number of service hours or machine faults, just to name a few. LiDAT allows you to be proactive and more responsive: organizing and maintaining your fleet for increased productivity.

### An Excellent After-Sales Service

The after-sales services can be customized to suit and respond to your specific needs. Several programs, such as ReMan, ReBuilt and Repair provide the perfect, economical solution, always including the manufacturer's quality and guarantee. A team of technicians, specialized to intervene on your machines, has all the latest-generation diagnostic tools, for a reduced down time of the machine. By following your chosen maintenance program, you will also obtain a higher resale price.

### Liebherr Tools

- Wide range of tools suitable for every type of application
- Tools designed for maximum productivity and durability
- Shape of buckets designed to assist the filling and stability of bulky materials during the transport stages
- Hydraulic quick coupler system



### Liebherr Lubricants

- Complete range of lubricants and coolants for your Liebherr engines
- Special service with product specialists available to listen to and advise you



### Original Lubricants

- Everything from one source, from genuine parts to original lubricants
- Competent advice on parts and lubricants
- Lubrication schedule creation

\* Availability depends on product and country



# Reliability



**World-Renowned  
Robustness**



### A Durable and Proven Design

In demanding applications Liebherr represents the benchmark for the robustness of its machines and the quality of the Liebherr components. Several casted parts are used for the design of the machine and are a testimony to the expertise and know-how of the manufacturer. With the large-sized attachments the R 976 crawler excavator is ideal for tough applications.

### A Proven Production Process and Advanced Technology

Liebherr development process integrates advanced digital tools in the fields of finite element computation, fatigue calculation and other simulation software. The results are then validated on special test benches prior to carrying out endurance tests on the entire machine in extreme conditions.

### High-Performance and Durable Undercarriage

Liebherr offers a large and unique range of welded or bolted undercarriages. The chamfered track pads have optimal manoeuvrability and are more resistant to wear on rocky terrain. The Liebherr travel drive is more powerful and better protected. The supporting rollers with double bearings guarantee improved load distribution and thus better durability over time.

### Specific Solutions Tailored to Customer Requirements

In the case a customer has a special request to address a specific application the customized solutions are designed and manufactured by Liebherr. This ensures successful integration and optimal performance of the excavator for the customer. As a sign of reliability Liebherr provides a manufacturer's warranty for the entire excavator including specific components as well as the electronics.

#### SCR System with Diesel Exhaust Fluid (AdBlue®)

- Diesel exhaust fluid level indicator on the display
- Liebherr design
- Complies with Stage IV standard
- No need for particle filters (DPF) and exhaust gas recycling (EGR)
- Simple system for enhanced reliability and less maintenance

#### Undercarriage

- Robust design for greater resistance and a better distribution of forces
- Easy and safe transport thanks to integrated securing hooks
- Three different types of undercarriage, welded or bolted

#### Key Components Developed by Liebherr

- Perfect harmonization of the machine elements, designed specifically for earthmoving and quarry applications
- Combustion engine, hydraulic pumps, swing mechanism, cylinders and electronic components are designed and manufactured by Liebherr
- Purpose built options such as special attachment lengths
- Specific tools and custom protection can be added at the factory

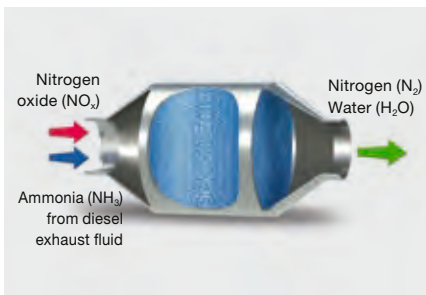

# Comfort



**Spacious Cab, Ergonomic  
and High-Visibility**

### A Spacious and Ergonomic Work Station

The cab offers a generous space for maximum comfort. Equipped, among other things, with a pneumatic seat with heater as standard (optional with airconditioning), controls connected to the seat and high-performance automatic air-conditioning, the cab creates a pleasant working environment. All the controls are precisely laid out in an intuitive manner for greater responsiveness and concentration while working. The cab is mounted on viscoelastic studs for significantly lower vibration.

### Fully Automatic Air-Conditioning

The automatic air-conditioning with touchscreen controls has several ventilation outlets for optimum ambient air in the cab.

### High Resolution Color Touchscreen

The color touchscreen is a true human-machine interface for controlling several comfort functions, such as the radio, and more operational functions, such as work modes, tool types and even the backup camera.

### A Spacious and Comfortable Cab

The cab of the R 976 is the most spacious cab in 90 tonne machine class. It offers unrivalled comfort for higher operator productivity during long working hours. With the highest level of protection on the market the impact-resistant windows offer maximum safety.



#### Control Screen

- 7" color touchscreen
- Several setting, control and surveillance options
- Robust and reliable design (Ingress Protection Rating IP65)
- Compatible high resolution video for displaying the rear camera image

#### Increased Visibility

- Rear camera integrated in the counterweight as standard and camera for side area monitoring, for rear visibility and heightened operating safety
- Optimized design of the whole upper-carriage providing the operator with an improved field of vision
- Secure emergency exit through the rear window

#### New Options

- Lighting in engine compartment
- LED headlights with adjustable current value
- 360° camera
- Follow me home (headlight cutoff delay)
- Windshield wiper on bottom part

# Easy Maintenance



**Simple and Safe  
Service Check Points**

### Ergonomic Access and Time-Saving

For maximum safety during servicing different types of platforms are available with a large central platform in particular for access to engine and hydraulic system components. The two-piece engine hood facilitates easier opening and closing. Fluid level monitoring, such as the engine oil level or urea tank level can be carried out quickly and easily from the touchscreen in the cab. The automatic lubrication system reduces precious servicing time while guaranteeing optimal lubrication of the excavator.

### Less Maintenance for more Productivity

The frequency of the service intervals is optimised to guarantee that each part is functioning optimally and that the maintenance tasks are only performed as necessary. Whether it is the interval for changing the hydraulic oil, which can be up to 8,000 hours, or the interval for changing the engine oil, every 1,000 hours, everything has been taken into account to reduce the frequency of interventions and thus limit the machine's downtime and lower costs.

### An Exhaust Gas Treatment without Maintenance

Thanks to its unique Liebherr design, the exhaust gas treatment is carried out in compliance with the Stage IV standards, without fitting a particle filter and exhaust gas recycling (EGR). This results in an output with no loss of productivity linked to the regeneration of these filters and, of course, no maintenance time or cost of spare parts associated with this technology.

### Expert Advice and Service Provisions

Liebherr offers an expert advice service. Qualified personnel will help you make the appropriate decisions to meet your needs: sales arguments based on the terrain, service agreements, advantageous repair alternatives, original parts management, and remote data transfer for fleet management.

#### LiDAT Data Transfer System

- Complete fleet management, all from one source
- Optimized economical performance of the machine park thanks to detailed view of the distribution of operating states and times
- Reports on capacity commitment and the use of the machine park can be called up daily via the Web portal
- Precise location of the machine
- Regional delimitation and fixed downtimes increase safety and reliability



#### Liebherr AdBlue Solution

- The crawler excavator has a stainless steel urea tank with capacity for 180 litres
- For maximum safety, the tank can be refilled using a filling pump and gun (optional)
- An 24 V electric field supply is also available for connecting the filling kit



#### Liebherr Warranties and Remanufacturing

- Significant warranties for the complete excavator and key components
- Optimal planning of all servicing activities
- Liebherr remanufacturing programme for processing worn components, conforming to the highest industrial standards

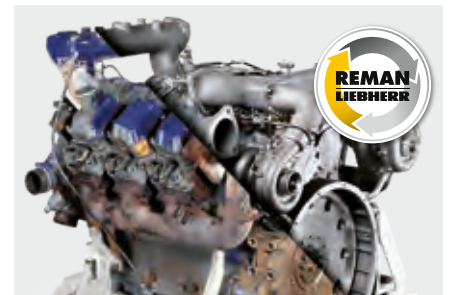

# Long Live Progress with the R 976

## Equipment

- Cast steel components
- Greater resistance to stresses
- Longer service life
- Safety check valves for stick and boom cylinders with integrated regeneration for less fuel consumption

## Tools

- Different levels of protection to suit the different areas of application
- New Liebherr Z-type tooth system





### **Operator's Cab**

- Comfortable and ergonomic design
- 7" high definition colour touch screen
- Wider for more comfort
- Impact resistant windows at the front and in the roof as standard
- Optional FOPS and FGPS protective guards

### **Accessibility**

- Maintenance platform in the engine compartment
- Broad, anti-slip side catwalks (right and left) as standard

### **Undercarriage**

- Robust structure thanks to the more rigid profile
- Molded two-tooth sprocket for a longer service life
- Two types of undercarriage available: an HD fixed-track gauge and LC-V variable-track gauge

# Long Live Progress with the R 976 Shovel

## Equipment

- Cast steel parts
- Parallel kinematics for powerful and regular digging
- Bucket cylinders positioned under the equipment for better protection against the elements
- Safety valves on boom cylinder for pipe burst protection

## Buckets

- The front shovel is the perfect shape for digging deep into the material and for a high filling rate
- Several levels of protection for the front shovel, depending on requirements
- Type I: non-abrasive materials, such as limestone without flint
- Type II: Shot material, or easily breakable rock (classification 3 to 4 according to DIN 18300)
- Type III: Highly abrasive materials, such as rocks with a high silica content, sandstone, granite, etc.
- Different design of blades: straight blade (loading) semi-delta (compacted materials) delta (direct excavation)







### **Operator's Cab**

- Comfortable and ergonomic design
- 7" high-resolution colour touch screen
- Wider for more comfort
- Impact resistant windows at the front and in the roof as standard
- Optional FOPS and FGPS protection guards
- Operator's cab with a fixed riser for a full view over the work area

# Technical Data



## Engine

<b>Rating per ISO 9249</b>	400 kW (544 HP) at 1,800 RPM
<b>Torque</b>	2,976 Nm at 1,200 RPM
<b>Model</b>	Liebherr D9508 A7 SCR
<b>Type</b>	8 cylinder V engine
Bore	128 mm
Stroke	157 mm
Displacement	16.16 l
<b>Engine operation</b>	4-stroke diesel Common-Rail
<b>Exhaust gas treatment</b>	SCR system (Selective Catalytic Reduction) emission standard stage IV
<b>Cooling system</b>	water-cooled and integrated motor oil cooler, after-cooled and fuel cooled
<b>Air cleaner</b>	dry-type air cleaner with pre-cleaner, primary and safety elements
<b>Fuel tank</b>	1,498 l
<b>Urea tank</b>	180 l
<b>Electrical system</b>	
Voltage	24 V
Batteries	2 x 180 Ah / 12 V
Starter	24 V / 7.8 kW
Alternator	three-phase current 28 V / 140 A
Engine idling	sensor controlled
<b>Motor management</b>	connection to the integrated excavator system controlling via CAN-BUS to the economical utilisation of the service that is available



## Hydraulic Controls

<b>Power distribution</b>	via control valves in single block with integrated safety valves
Flow summation	to boom and stick
Closed-loop circuit	for uppercarriage swing drive
<b>Servo circuit</b>	electro-hydraulic control
Attachment and swing	proportional via joystick levers
Travel	– with proportionally functioning foot pedals or adjusted with plugable levers – speed pre-selection
<b>Additional functions</b>	proportional regulation via foot pedals or joystick toggle switch



## Hydraulic System

<b>Hydraulic pump</b>	
for attachment and travel drive	two Liebherr variable displacement, swashplate pumps
Max. flow	2 x 498 l/min.
Max. pressure for swing drive	350 bar reversible, variable displacement, swashplate pump, closed-loop circuit
Max. flow	315 l/min.
Max. pressure	350 bar
<b>Pump regulation</b>	electro-hydraulic with electronic engine speed sensing regulation, minimum flow adjustment, flow compensation, high flow
<b>Hydraulic tank</b>	536 l
<b>Hydraulic system</b>	1,134 l
<b>Hydraulic oil filter</b>	2 full flow filters in return line with integrated fine filter area (5 µm)
<b>Cooling system</b>	cooler for transmission pump oil and cooler for oil and condenser of air-conditioning with hydrostatically controlled fan drives
<b>MODE selection</b>	adjustment of engine and hydraulic performance via a mode pre-selector to match application, e.g. for especially economical and environmen- tally friendly operation or for maximum digging performance and heavy-duty jobs
<b>RPM adjustment</b>	stepless adjustment of engine output via RPM at each selected mode
<b>Tool Control</b>	10 preadjustable pump flows and pressures for add-on tools



## Swing Drive

<b>Drive</b>	Liebherr swashplate motor with integrated brake valve
<b>Transmission</b>	Liebherr compact planetary reduction gears
<b>Swing ring</b>	Liebherr, sealed race ball bearing swing ring, internal teeth
<b>Swing speed</b>	0 – 5.9 RPM stepless
<b>Swing torque</b>	295 kNm
<b>Holding brake</b>	wet multi-disc (spring applied, pressure released)



## Operator's Cab

<b>Cab</b>	work headlights integrated in the ceiling, a door with a sliding window (can be opened on both sides), large stowing and depositing possibilities, shock-absorbing suspension, sounddamping insulating, tinted laminated safety glass, separate window shades for the sunroof window and windscreen, cigarette lighter and 12 V plug, storage bins, lunchbox, cup holder
<b>Operator's seat</b>	Liebherr-Comfort seat, airsprung with automatic weight adjustment, vertical and longitudinal seat damping including consoles and joysticks. Seat and armrests adjustable separately and in combination, seat heating as standard
<b>Control system</b>	arm consoles, swinging with the seat
<b>Operation and displays</b>	large high-resolution colour display with self-explanatory operation via touchscreen, video, versatile adjusting, control and monitoring facilities, e.g. climate control, implement and tool parameters
<b>Air-conditioning</b>	standard automatic air-conditioning fully controlled on the display, ambient air function, fast de-icing and demisting at the press of a button, air vents can be operated via a menu. Ambient air and fresh air filters can be easily replaced and are accessible from outside and standing on the ground. Heating-cooling unit, designed for extreme outside temperatures, sensors for solar radiation, inside and outside temperatures

## Undercarriage

<b>Versions</b>	
HD	gauge 3,600 mm
LC-V	gauge 3,590 mm
<b>Drive</b>	Liebherr swashplate motor with brake valves on both sides
<b>Transmission</b>	Liebherr compact planetary reduction gear
<b>Maximum travel speed</b>	low range 2.7 km/h high range 4.3 km/h
<b>Net drawbar pull on crawler</b>	568 kN
<b>Track components</b>	D9G, maintenance-free
<b>Track rollers/Carrier rollers</b>	HD: 8/2 LC-V: 9/3
<b>Tracks</b>	sealed and greased
<b>Track pads</b>	double grouser
<b>Holding brake</b>	wet multi-disc (spring applied, pressure released)
<b>Brake valves</b>	outside the travel motor
<b>Lashing eyes</b>	integrated



## Attachment

<b>Type</b>	combination of resistant steel plates and cast steel components
<b>Hydraulic cylinders</b>	Liebherr cylinders with special seal-system, shock protection
<b>Bearings</b>	sealed, low maintenance
<b>Lubrication</b>	automatic central lubrication system (except link and tilt geometry)
<b>Hydraulic connections</b>	pipes and hoses equipped with SAE split-flange connections
<b>Buckets</b>	standard equipped with Liebherr tooth system

# Dimensions

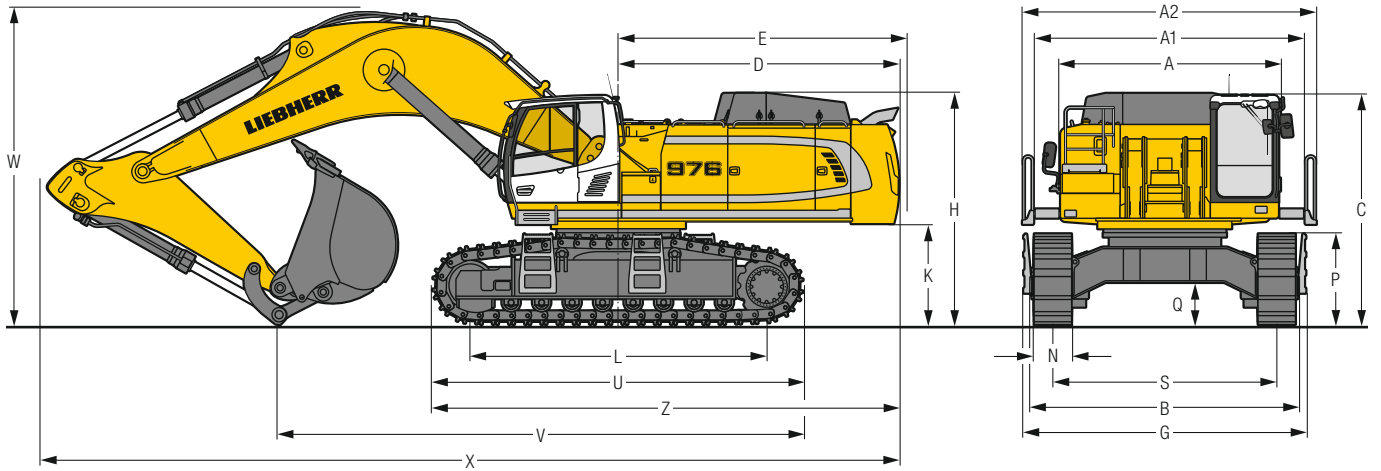

HD	mm		
A	3,565		
A1	4,355		
A2	4,730		
C	3,695/3,890*		
D	4,515		
E	4,640		
H	3,725		
K	1,620		
L	4,770		
P	1,460		
Q	682		
S	3,600		
U	5,960		
N	500	600	750
B	4,290	4,290	4,350
G	4,540	4,540	4,540
Z	7,490		

\* with FOPS top guard

\*\* transport position

LC-V	mm		
A	3,565		
A1	4,355		
A2	4,730		
C	3,835/4,030*		
D	4,515		
E	4,640		
H	3,865		
K	1,755		
L	5,160		
P	1,495		
Q	955		
S	2,750**/3,590		
U	6,335		
N	500	600	750
B	3,490**	3,490**	3,500**
G	3,870**	3,870**	3,870**
Z	7,680		

HD-Undercarriage	Stick length	Mono boom	Mono boom	Mono boom
	m	7.20 m mm	8.60 m mm	10.50 m mm
V	2.90	8,450	–	–
	3.30	8,200	9,950	–
	3.80	8,100	9,850	11,900
	4.70	7,950	9,650	11,700
	5.80	–	9,650	11,550
W	2.90	5,100	–	–
	3.30	5,250	5,450	–
	3.80	5,550	5,600	5,900
	4.70	6,050	6,000	6,100
	5.80	–	6,800	6,800
X	2.90	13,800	–	–
	3.30	13,500	14,900	–
	3.80	13,400	14,750	16,650
	4.70	13,150	14,550	16,450
	5.80	–	14,150	16,150

LC-V-Undercarriage	Stick length	Mono boom	Mono boom	Mono boom
	m	7.20 m mm	8.60 m mm	10.50 m mm
V	2.90	8,600	–	–
	3.30	8,350	10,100	–
	3.80	8,200	10,000	12,050
	4.70	8,050	9,800	11,850
	5.80	–	9,750	11,700
W	2.90	5,150	–	–
	3.30	5,350	5,500	–
	3.80	5,600	5,700	6,000
	4.70	6,150	6,000	6,200
	5.80	–	6,750	6,800
X	2.90	13,800	–	–
	3.30	13,500	14,900	–
	3.80	13,450	14,750	16,650
	4.70	13,250	14,550	16,500
	5.80	–	14,250	16,250

# Backhoe Bucket

## with Mono Boom 7.20 m and Counterweight 14.1 t

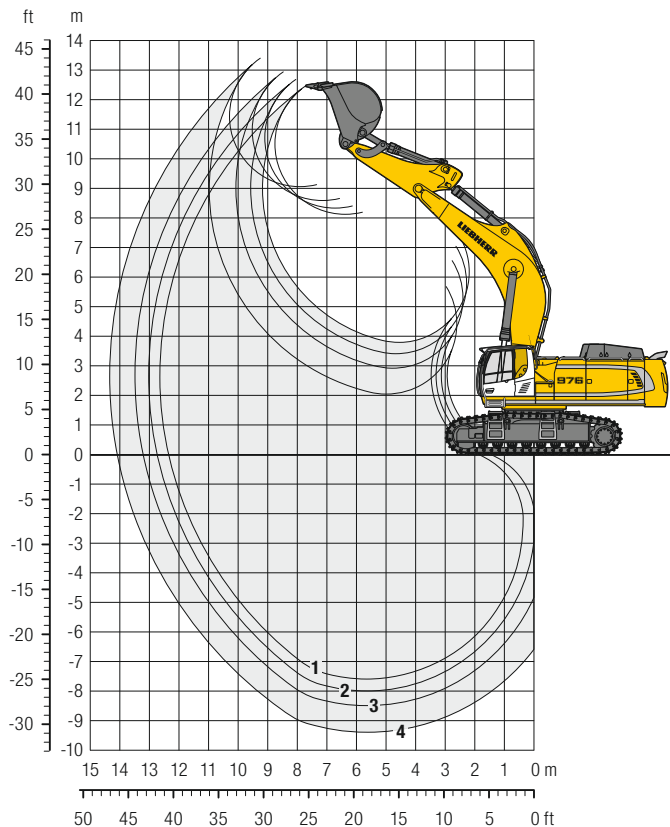

### Digging Envelope

		1	2	3	4
Stick length	m	2.90	3.30	3.80	4.70
Max. digging depth	m	7.45	7.85	8.35	9.25
Max. reach at ground level	m	12.30	12.70	13.20	14.05
Max. dumping height	m	8.25	8.50	8.75	9.20
Max. teeth height	m	12.60	12.85	13.10	13.55

### Forces

		1	2	3	4
Max. digging force (ISO 6015)	kN	390	361	329	284
Max. breakout force (ISO 6015)	kN	485	485	485	485
Max. digging force (SAE J1179)	kN	374	347	317	276
Max. breakout force (SAE J1179)	kN	437	437	437	437

### Operating Weight and Ground Pressure

The operating weight includes the basic machine with counterweight 14.1 t, mono boom 7.20 m, stick 2.90 m and bucket 5.20 m<sup>3</sup> (4,600 kg).

Undercarriage		HD			LC-V		
Pad width	mm	500	600	750	500	600	750
Weight	kg	85,800	86,600	87,700	91,200	92,000	93,100
Ground pressure	kg/cm <sup>2</sup>	1.65	1.39	1.13	1.64	1.38	1.12

Optional: counterweight 16.0 t

(counterweight 16.0 t increases the operating weight by 1,900 kg and ground pressure by 0.04 kg/cm<sup>2</sup>) see load tables on page 30

### Buckets Machine stability per ISO 10567\* (75% of tipping capacity)

	Cutting width mm	Capacity ISO 7451 m <sup>3</sup>	Weight kg	HD-Undercarriage (with track pads 600 mm)				LC-V-Undercarriage (with track pads 600 mm)					
				Stick length (m)				Stick length (m)					
				2.90	3.30	3.80	4.70	2.90	3.30	3.80	4.70		
STD <sup>1)</sup>	1,400	2.70	3,450	▲	▲	▲	▲	▲	▲	▲	▲	▲	▲
	1,600	3.20	3,750	▲	▲	▲	▲	▲	▲	▲	▲	▲	▲
	1,800	3.80	4,000	▲	▲	▲	▲	▲	▲	▲	▲	▲	▲
	1,950	4.30	4,200	▲	▲	▲	▲	▲	▲	▲	▲	▲	▲
	2,150	4.80	4,450	▲	▲	▲	▲	▲	▲	▲	▲	▲	■
	2,300	5.20	4,600	▲	▲	▲	▲	▲	▲	▲	▲	▲	■
	2,300	5.80	4,800	▲	■	▲	△	▲	▲	▲	■	▲	■
HD <sup>2)</sup>	2,600	6.60	5,100	■	▲	■	△	■	■	▲	▲	▲	△
	1,400	2.60	3,800	▲	▲	▲	▲	▲	▲	▲	▲	▲	▲
	1,600	3.10	4,250	▲	▲	▲	▲	▲	▲	▲	▲	▲	▲
	1,800	3.60	4,400	▲	▲	▲	▲	▲	▲	▲	▲	▲	▲
	1,950	4.10	4,800	▲	▲	▲	▲	▲	▲	▲	▲	▲	▲
	2,150	4.60	5,050	▲	▲	▲	■	▲	▲	▲	▲	▲	■
	2,300	5.20	5,400	▲	▲	■	■	▲	▲	▲	▲	▲	▲
HDV <sup>3)</sup>	2,300	5.60	5,450	▲	▲	▲	△	▲	▲	▲	■	▲	■
	2,450	6.20	5,900	■	▲	■	△	■	■	▲	▲	▲	△
	1,950	4.20	5,700	▲	▲	▲	■	▲	▲	▲	▲	▲	▲
	2,150	4.70	6,000	▲	▲	■	■	▲	▲	▲	▲	▲	▲
	2,300	5.20	6,300	▲	■	▲	△	▲	▲	▲	■	▲	■
	2,300	5.70	6,400	■	▲	■	△	▲	■	▲	▲	▲	△

\* Indicated loads are based on ISO 10567, at maximum reach, and may be swung 360° on firm and even ground

<sup>1)</sup> Standard bucket with Liebherr teeth Z 90

<sup>2)</sup> HD bucket with Liebherr teeth Z 90

<sup>3)</sup> HDV bucket with Liebherr teeth Z 90

Other buckets available upon request

Max. material weight ▲ = ≤ 2.0 t/m<sup>3</sup>, ■ = ≤ 1.8 t/m<sup>3</sup>, ▲ = ≤ 1.65 t/m<sup>3</sup>, ■ = ≤ 1.5 t/m<sup>3</sup>, - = not authorised

# Lift Capacities

with Mono Boom 7.20 m, Counterweight 14.1 t and Track Pads 600 mm

### Stick 2.90 m

Under-carriage	m	3.0 m		4.5 m		6.0 m		7.5 m		9.0 m		10.5 m		m	
		HD	LC-V	HD	LC-V	HD	LC-V	HD	LC-V	HD	LC-V	HD	LC-V		
13.5															
12.0															
10.5															
9.0													23.9*	23.9*	6.4
7.5													21.3*	21.3*	8.0
6.0													19.5	20.2*	9.0
4.5													16.9	19.9*	9.7
3.0													15.5	19.0	10.1
1.5													14.7	19.0	10.3
0													14.6	18.9	10.2
-1.5													15.0	19.5	9.9
-3.0	40.6*	40.6*	38.5*	38.5*	29.9	35.1*	21.6	28.0*	16.9	22.1			16.1	21.1*	9.3
-4.5			38.9*	38.9*	30.2	31.4*	21.8	25.0*					18.6	20.7*	8.5
-6.0			30.5*	30.5*	24.6*	24.6*							19.2*	19.2*	7.1
-7.5															
-9.0															
-10.5															

### Stick 3.30 m

Under-carriage	m	3.0 m		4.5 m		6.0 m		7.5 m		9.0 m		10.5 m		m		
		HD	LC-V	HD	LC-V	HD	LC-V	HD	LC-V	HD	LC-V	HD	LC-V			
13.5																
12.0																
10.5																
9.0														20.1*	20.1*	7.0
7.5														17.3*	17.3*	8.4
6.0														15.9	17.1*	10.1
4.5														14.6	17.3*	10.5
3.0														13.9	18.0*	10.6
1.5														13.8	17.8	10.6
0														14.1	18.3	10.3
-1.5														15.1	19.7	9.7
-3.0	36.6*	36.6*	36.8*	36.8*	29.9	35.8*	21.5	28.3*	16.7	22.0			17.1	20.1*	8.9	
-4.5			41.3*	41.3*	30.0	32.6*	21.6	25.9*					19.1*	19.1*	7.7	
-6.0			33.5*	33.5*	26.8*	26.8*	20.1*	20.1*								
-7.5																
-9.0																
-10.5																

### Stick 3.80 m

Under-carriage	m	3.0 m		4.5 m		6.0 m		7.5 m		9.0 m		10.5 m		m		
		HD	LC-V	HD	LC-V	HD	LC-V	HD	LC-V	HD	LC-V	HD	LC-V			
13.5																
12.0																
10.5																
9.0														18.3*	18.3*	7.7
7.5														15.7*	15.7*	9.0
6.0														14.7*	14.7*	10.0
4.5														14.5*	14.5*	10.6
3.0														13.6	14.7*	11.0
1.5														13.0	15.2*	11.1
0														12.9	16.1*	11.0
-1.5														13.7	17.7	10.8
-3.0	32.7*	32.7*	34.9*	34.9*	29.8	36.3*	21.5	28.5*	16.6	21.9			13.9	18.2	10.3	
-4.5	48.1*	48.1*	43.8*	43.8*	29.8	33.8*	21.4	26.8*	16.6	21.2*			15.6	19.3*	9.5	
-6.0			36.9*	36.9*	29.0*	29.0*	21.7	22.6*					18.8*	18.8*	8.3	
-7.5			19.8*	19.8*									17.2*	17.2*	6.5	
-9.0																
-10.5																

### Stick 4.70 m

Under-carriage	m	3.0 m		4.5 m		6.0 m		7.5 m		9.0 m		10.5 m		m		
		HD	LC-V	HD	LC-V	HD	LC-V	HD	LC-V	HD	LC-V	HD	LC-V			
13.5																
12.0																
10.5																
9.0														12.6*	12.6*	8.9
7.5														11.7*	11.7*	10.1
6.0														11.2*	11.2*	10.9
4.5														11.1*	11.1*	11.5
3.0														11.2*	11.2*	11.8
1.5														11.4	12.6*	11.9
0														11.6	13.1*	11.6
-1.5	18.1*	18.1*	32.5*	32.5*	29.8	36.7*	21.4	28.6*	16.5	21.8			12.2	14.6*	11.2	
-3.0	27.4*	27.4*	43.5*	43.5*	29.5	35.4*	21.1	27.7*	16.3	21.6			13.3	17.0*	10.5	
-4.5	39.3*	39.3*	41.9*	41.9*	29.6	32.0*	21.2	25.2*	16.5	19.5*			15.5	17.7*	9.4	
-6.0	44.9*	44.9*	33.5*	33.5*	25.9*	25.9*	19.4*	19.4*					16.9*	16.9*	8.0	
-7.5																
-9.0																
-10.5																

Height  
 Can be slewed through 360°  
 In longitudinal position of undercarriage  
 Max. reach  
 \* Limited by hydr. capacity

The load values are quoted in tons (t) at stick end (without bucket), and may be swung 360° on firm and even ground. Adjacent values are valid for the undercarriage when in the longitudinal position. Capacities are valid for 600 mm wide track pads. Indicated loads are based on ISO 10567 standard and do not exceed 75% of tipping or 87% of hydraulic capacity (indicated via \*). Without bucket cylinder, link and lever the lift capacities will increase by 1,320 kg. Lifting capacity of the excavator is limited by machine stability and hydraulic capacity. According to European Standard, EN 474-5: In the European Union excavators have to be equipped with an overload warning device, a load diagram and automatic safety check valves on hoist cylinders and stick cylinder(s), when they are used for lifting operations which require the use of lifting accessories.

# Backhoe Bucket

## with Mono Boom 8.60 m and Counterweight 14.1 t

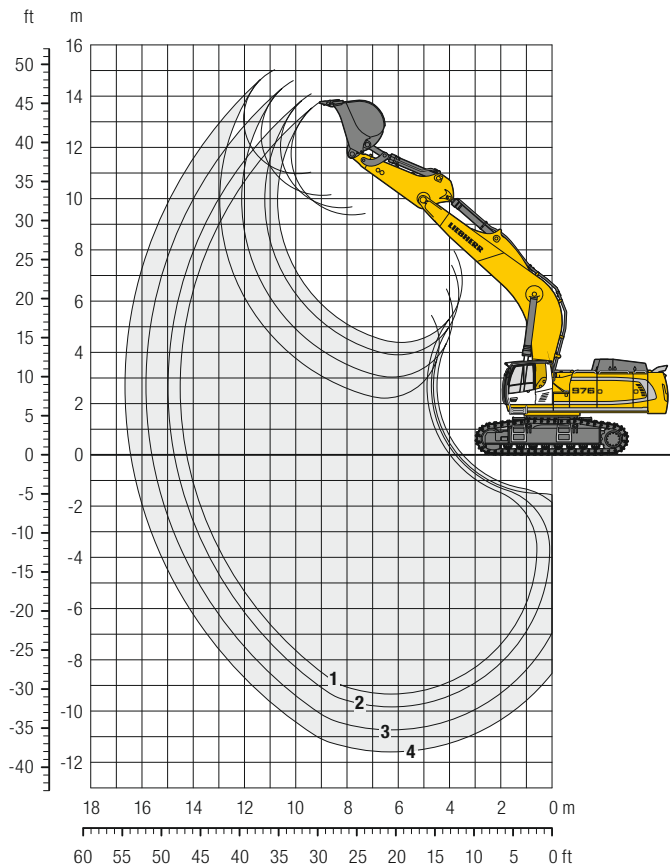

### Digging Envelope

		1	2	3	4
Stick length	m	3.30	3.80	4.70	5.80
Max. digging depth	m	9.20	9.70	10.60	11.45
Max. reach at ground level	m	14.20	14.70	15.60	16.40
Max. dumping height	m	9.50	9.80	10.30	11.10
Max. teeth height	m	13.90	14.20	14.75	15.15

### Forces

		1	2	3	4
Max. digging force (ISO 6015)	kN	361	329	284	249
Max. breakout force (ISO 6015)	kN	485	485	485	356
Max. digging force (SAE J1179)	kN	347	317	276	237
Max. breakout force (SAE J1179)	kN	437	437	437	315

### Operating Weight and Ground Pressure

The operating weight includes the basic machine with counterweight 14.1 t, mono boom 8.60 m, stick 3.80 m and bucket 3.80 m<sup>3</sup> (4,000 kg).

Undercarriage		HD			LC-V		
Pad width	mm	500	600	750	500	600	750
Weight	kg	86,500	87,200	88,300	91,800	92,600	93,700
Ground pressure	kg/cm <sup>2</sup>	1.67	1.40	1.14	1.65	1.39	1.12

Optional: counterweight 16.0 t

(counterweight 16.0 t increases the operating weight by 1,900 kg and ground pressure by 0.04 kg/cm<sup>2</sup>) see load tables on pages 31 and 32

### Buckets Machine stability per ISO 10567\* (75% of tipping capacity)

	Cutting width mm	Capacity ISO 7451 m <sup>3</sup>	Weight kg	HD-Undercarriage (with track pads 600 mm)				LC-V-Undercarriage (with track pads 600 mm)			
				Stick length (m)				Stick length (m)			
				3.30	3.80	4.70	5.80	3.30	3.80	4.70	5.80
STD <sup>1)</sup>	1,600	3.20	3,750	▲	▲	▲	–	▲	▲	▲	–
	1,800	3.80	4,000	▲	▲	▲	–	▲	▲	■	–
	1,950	4.30	4,200	■	▲	△	–	▲	■	■	–
	2,150	4.80	4,450	▲	■	△	–	■	■	△	–
	2,300	5.20	4,600	■	△	–	–	▲	■	△	–
HD <sup>2)</sup>	2,300	5.80	4,800	△	△	–	–	△	△	–	–
	1,600	3.10	4,250	▲	▲	■	–	▲	▲	▲	–
	1,800	3.60	4,400	▲	▲	▲	–	▲	▲	■	–
	1,950	4.10	4,800	■	▲	△	–	▲	■	■	–
	2,150	4.60	5,050	▲	△	△	–	▲	■	△	–
STD <sup>3)</sup>	2,300	5.20	5,400	△	△	–	–	■	△	–	–
	2,300	5.60	5,450	△	–	–	–	△	△	–	–
	1,750	3.00	3,150	–	–	–	▲	–	–	–	▲
	1,950	3.50	3,450	–	–	–	▲	–	–	–	■
	2,150	4.00	3,600	–	–	–	△	–	–	–	■
HD <sup>4)</sup>	2,150	4.50	3,900	–	–	–	△	–	–	–	△
	1,800	2.50	3,850	–	–	–	▲	–	–	–	▲
	2,000	3.00	4,100	–	–	–	■	–	–	–	■
	2,150	3.50	4,450	–	–	–	△	–	–	–	■

\* Indicated loads are based on ISO 10567, at maximum reach, and may be swung 360° on firm and even ground

<sup>1)</sup> Standard bucket with Liebherr teeth Z 90

<sup>2)</sup> HD bucket with Liebherr teeth Z 90

<sup>3)</sup> Standard bucket from R 966 Litronic with Liebherr teeth Z 70

<sup>4)</sup> HD bucket from R 966 Litronic with Liebherr teeth Z 90

Other buckets available upon request

Max. material weight ▲ = ≤ 2.0 t/m<sup>3</sup>, ■ = ≤ 1.8 t/m<sup>3</sup>, ▲ = ≤ 1.65 t/m<sup>3</sup>, ■ = ≤ 1.5 t/m<sup>3</sup>, – = not authorised







# Backhoe Bucket

## with Mono Boom 10.50 m and Counterweight 16.0 t

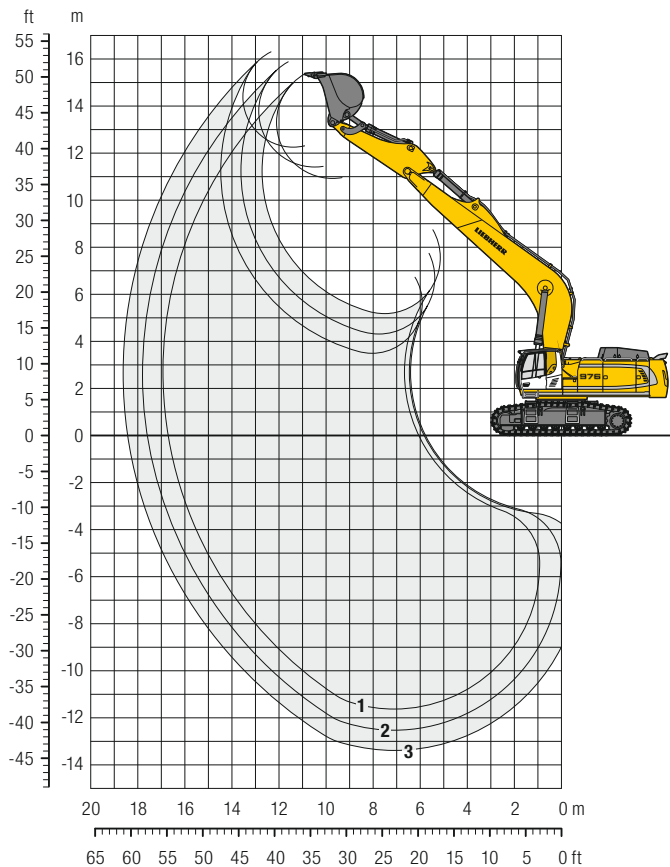

### Digging Envelope

		1	2	3
Stick length	m	3.80	4.70	5.80
Max. digging depth	m	11.50	12.40	13.25
Max. reach at ground level	m	16.70	17.55	18.40
Max. dumping height	m	11.05	11.55	12.40
Max. teeth height	m	15.50	16.00	16.45

### Forces

		1	2	3
Max. digging force (ISO 6015)	kN	329	284	249
Max. breakout force (ISO 6015)	kN	485	485	356
Max. digging force (SAE J1179)	kN	317	276	237
Max. breakout force (SAE J1179)	kN	437	437	315

### Operating Weight and Ground Pressure

The operating weight includes the basic machine with counterweight 16.0 t, mono boom 10.50 m, stick 4.70 m and bucket 2.20 m<sup>3</sup> (3,100 kg).

Undercarriage		HD			LC-V		
Pad width	mm	500	600	750	500	600	750
Weight	kg	89,000	89,800	90,900	94,400	95,200	96,300
Ground pressure	kg/cm <sup>2</sup>	1.72	1.44	1.17	1.70	1.42	1.15

### Buckets Machine stability per ISO 10567\* (75% of tipping capacity)

	Cutting width mm	Capacity ISO 7451 m <sup>3</sup>	Weight kg	HD-Undercarriage (with track pads 600 mm)			LC-V-Undercarriage (with track pads 600 mm)		
				Stick length (m)			Stick length (m)		
				3.80	4.70	5.80	3.80	4.70	5.80
STD <sup>1)</sup>	1,250	2.20	3,100	▲	▲	–	▲	▲	–
	1,400	2.70	3,450	▲	▲	–	▲	■	–
	1,600	3.20	3,750	■	△	–	■	△	–
	1,800	3.80	4,000	△	–	–	△	△	–
	1,950	4.30	4,200	–	–	–	△	–	–
HD <sup>2)</sup>	1,400	2.60	3,800	■	■	–	▲	■	–
	1,600	3.10	4,250	■	△	–	▲	△	–
	1,800	3.60	4,400	△	–	–	△	–	–
	1,950	4.10	4,800	–	–	–	△	–	–
STD <sup>3)</sup>	1,150	1.50	2,550	–	–	▲	–	–	▲
	1,350	2.00	2,750	–	–	▲	–	–	▲
	1,550	2.50	2,950	–	–	▲	–	–	■
	1,750	3.00	3,150	–	–	△	–	–	■
	1,950	3.50	3,450	–	–	–	–	–	△
	1,400	1.50	3,250	–	–	▲	–	–	▲
HD <sup>4)</sup>	1,600	2.00	3,550	–	–	■	–	–	▲
	1,800	2.50	3,850	–	–	△	–	–	▲
	2,000	3.00	4,100	–	–	–	–	–	△

\* Indicated loads are based on ISO 10567, at maximum reach, and may be swung 360° on firm and even ground

<sup>1)</sup> Standard bucket with Liebherr teeth Z 90

<sup>2)</sup> HD bucket with Liebherr teeth Z 90

<sup>3)</sup> Standard bucket from R 966 Litronic<sup>2</sup> with Liebherr teeth Z 70

<sup>4)</sup> HD bucket from R 966 Litronic<sup>2</sup> with Liebherr teeth Z 90

Other buckets available upon request

Max. material weight ▲ = ≤ 2.0 t/m<sup>3</sup>, ■ = ≤ 1.8 t/m<sup>3</sup>, ▲ = ≤ 1.65 t/m<sup>3</sup>, ■ = ≤ 1.5 t/m<sup>3</sup>, – = not authorised



## Stick 5.80 m

Under-carriage	3.0 m		4.5 m		6.0 m		7.5 m		9.0 m		10.5 m		12.0 m		13.5 m		15.0 m		16.5 m		m			
	m																							
HD	13.5													9.2*	9.2*					9.4*	9.4*	12.3		
	12.0																				9.2*	9.2*	13.5	
	10.5																				9.0*	9.0*	14.5	
	9.0														9.0*	9.0*	8.8*	8.8*	8.4	8.9*	8.0	8.7*	15.2	
	7.5													9.5*	9.5*	9.1*	9.1*	8.3	8.9*		7.3	8.6*	15.8	
	6.0													10.2*	10.2*	9.6*	9.6*	8.1	9.1*		6.8	8.5*	16.2	
	4.5									14.3*	14.3*	12.3*	12.3*	11.0*	11.0*	9.6	10.1*	7.9	9.5*		6.5	8.6*	16.4	
	3.0									15.9*	15.9*	13.4*	13.4*	11.1	11.8*	9.2	10.6*	7.6	9.8*	6.3	8.5	6.3	8.5	16.5
	1.5									15.9	17.4*	12.8	14.5*	10.5	12.5*	8.8	11.2*	7.3	9.9		6.2	8.4	16.5	
	0									15.0	18.5*	12.2	15.3*	10.1	13.2*	8.4	11.3	7.1	9.6		6.2	8.4	16.3	
	-1.5									14.5	19.2*	11.7	15.9	9.7	13.1	8.2	11.1	7.0	9.5		6.3	8.7	16.0	
	-3.0							18.4	24.0*	14.2	19.5*	11.4	15.6	9.5	12.9	8.0	10.9	6.9	9.4		6.6	9.0	15.5	
	-4.5					20.8*	20.8*	18.4	23.7*	14.1	19.4*	11.3	15.5	9.4	12.8	8.0	10.9				7.1	9.7	14.8	
-6.0	16.1*	16.1*	20.3*	20.3*	26.5	28.4*	18.6	22.8*	14.2	18.8*	11.4	15.6	9.5	12.9	8.2	11.1				7.9	10.5*	14.0		
-7.5	22.7*	22.7*	28.4*	28.4*	26.2*	26.2*	19.0	21.3*	14.5	17.7*	11.7	14.8*	9.8	12.3*						9.1	10.6*	12.9		
-9.0	31.3*	31.3*	29.1*	29.1*	23.1*	23.1*	19.0*	19.0*	15.1	15.7*	12.2	12.7*								10.5*	10.5*	11.6		
-10.5			22.8*	22.8*	18.4*	18.4*	15.0*	15.0*	11.7*	11.7*										9.9*	9.9*	9.6		
LC-V	13.5													9.1*	9.1*					9.4*	9.4*	12.3		
	12.0																				9.1*	9.1*	13.5	
	10.5																				9.0*	9.0*	14.5	
	9.0														9.1*	9.1*	8.8*	8.8*	8.9	8.9*	8.5	8.7*	15.2	
	7.5														9.6*	9.6*	9.1*	9.1*	8.8	8.9*	7.8	8.6*	15.8	
	6.0									12.8*	12.8*	11.3*	11.3*	10.3*	10.3*	9.6*	9.6*	8.6	9.2*		7.3	8.5*	16.2	
	4.5									14.5*	14.5*	12.4*	12.4*	11.1*	11.1*	10.1	10.1*	8.4	9.5*		6.9	8.6*	16.4	
	3.0									16.1*	16.1*	13.5*	13.5*	11.7	11.8*	9.7	10.7*	8.1	9.9*	6.7	8.9*	6.7	8.7*	16.5
	1.5									16.7	17.5*	13.5	14.6*	11.1	12.6*	9.3	11.2*	7.8	10.2*		6.6	9.0*	16.5	
	0									15.9	18.5*	12.9	15.4*	10.7	13.2*	9.0	11.7*	7.6	10.5*		6.6	9.3*	16.3	
	-1.5									15.4	19.2*	12.4	16.0*	10.3	13.7*	8.7	12.0*	7.4	10.7*		6.8	9.9*	16.0	
	-3.0							19.5	24.0*	15.1	19.5*	12.2	16.3*	10.1	13.9*	8.6	12.1*	7.4	10.6*		7.1	10.1*	15.5	
	-4.5			14.5*	14.5*	21.4*	21.4*	19.5	23.6*	15.0	19.3*	12.1	16.2*	10.0	13.8*	8.6	11.9*				7.7	10.3*	14.8	
-6.0	16.6*	16.6*	20.9*	20.9*	28.1	28.2*	19.8	22.7*	15.1	18.7*	12.2	15.7*	10.1	13.4*	8.7	11.2*				8.5	10.5*	14.0		
-7.5	23.4*	23.4*	29.2*	29.2*	26.0*	26.0*	20.2	21.2*	15.4	17.5*	12.5	14.7*	10.5	12.1*						9.8	10.6*	12.9		
-9.0	32.2*	32.2*	28.6*	28.6*	22.8*	22.8*	18.7*	18.7*	15.4*	15.4*	12.5*	12.5*								10.4*	10.4*	11.6		
-10.5					17.9*	17.9*	14.5*	14.5*	11.1*	11.1*										9.8*	9.8*	9.6		

 Height 
  Can be slewed through 360° 
  In longitudinal position of undercarriage 
  Max. reach \* Limited by hydr. capacity

The load values are quoted in tons (t) at stick end (without bucket), and may be swung 360° on firm and even ground. Adjacent values are valid for the undercarriage when in the longitudinal position. Capacities are valid for 600 mm wide track pads. Indicated loads are based on ISO 10567 standard and do not exceed 75% of tipping or 87% of hydraulic capacity (indicated via \*). Without bucket cylinder, link and lever the lift capacities will increase by 1,320 kg. Lifting capacity of the excavator is limited by machine stability and hydraulic capacity.

According to European Standard, EN 474-5: In the European Union excavators have to be equipped with an overload warning device, a load diagram and automatic safety check valves on hoist cylinders and stick cylinder(s), when they are used for lifting operations which require the use of lifting accessories.



# Lift Capacities

with Mono Boom 8.60 m, Counterweight 16.0 t and Track Pads 600 mm

### Stick 3.30 m

Under-carriage m	3.0 m		4.5 m		6.0 m		7.5 m		9.0 m		10.5 m		12.0 m		13.5 m		15.0 m		16.5 m		m	
13.5																						
12.0																						
10.5										16.4*	16.4*									16.5*	16.5*	9.1
9.0										16.0*	16.0*									15.9*	15.9*	10.3
7.5										16.6*	16.6*	15.7*	15.7*							14.2*	15.7*	11.1
6.0							18.4*	18.4*	16.6*	16.6*	15.7*	15.7*								12.8*	15.6*	11.6
4.5							20.5*	20.5*	17.8*	17.8*	15.3*	16.1*								11.9*	15.4*	12.0
3.0							22.9*	22.9*	18.7*	19.1*	14.8*	16.9*								11.4*	14.9*	12.1
1.5							22.9*	25.1*	17.8*	20.5*	14.3*	17.7*	11.6	15.1						11.3*	14.7*	12.1
0							21.3*	27.0*	16.6*	22.0*	13.5*	17.7*	11.4	14.9						11.5*	15.1*	11.8
-1.5						29.5	31.7*	21.1	26.6*	16.4	21.8	13.4	17.6							12.1*	15.9*	11.4
-3.0						27.5*	27.5*	29.8	31.1*	21.2	25.4*	16.5	20.9*	13.5	17.0*					13.3*	16.5*	10.7
-4.5						33.7*	33.7*	27.9*	27.9*	21.6	23.0*	16.8	18.6*							15.5*	16.3*	9.7
-6.0						27.3*	27.3*	22.9*	22.9*	18.3*	18.3*									15.4*	15.4*	8.3
-7.5																						
-9.0																						
-10.5																						

### Stick 3.80 m

Under-carriage m	3.0 m		4.5 m		6.0 m		7.5 m		9.0 m		10.5 m		12.0 m		13.5 m		15.0 m		16.5 m		m	
13.5																						
12.0																						
10.5										15.1*	15.1*									16.3*	16.3*	8.3
9.0										15.0*	15.0*	14.8*	14.8*							15.3*	15.3*	9.8
7.5										15.8*	15.8*	14.9*	14.9*							14.9*	14.9*	10.8
6.0										19.5*	19.5*	17.0*	17.0*	15.5*	15.5*					13.2	14.6*	11.6
4.5										22.0*	22.0*	18.4*	18.4*	14.9	16.3*	12.0	15.0*			11.9	14.5*	12.1
3.0										23.2	24.3*	18.0	19.9*	14.3	17.2*	11.7	15.1			11.2	14.5*	12.5
1.5										22.0	25.9*	17.2	21.0*	13.8	17.9*	11.4	14.8			10.7	14.0	12.6
0										21.3	26.7*	16.6	21.7*	13.4	17.7	11.2	14.6			10.6	13.9	12.5
-1.5						29.3	31.3*	21.0	26.7*	16.3	21.7	13.2	17.5							10.8	14.1	12.3
-3.0						29.5	32.0*	21.0	25.8*	16.3	21.1*	13.3	17.5							11.3	14.8	11.9
-4.5						29.5*	29.5*	21.0	25.8*	16.3	21.1*	13.3	17.5							12.3	15.7*	11.2
-6.0						29.5*	29.5*	21.0	25.8*	16.3	21.1*	13.3	17.5							14.1	15.7*	10.3
-7.5						30.4*	30.4*	24.9*	24.9*	20.1*	20.1*									15.2*	15.2*	9.0
-9.0																						
-10.5																						

Height Can be slewed through 360° In longitudinal position of undercarriage Max. reach \* Limited by hydr. capacity

The load values are quoted in tons (t) at stick end (without bucket), and may be swung 360° on firm and even ground. Adjacent values are valid for the undercarriage when in the longitudinal position. Capacities are valid for 600 mm wide track pads. Indicated loads are based on ISO 10567 standard and do not exceed 75% of tipping or 87% of hydraulic capacity (indicated via \*). Without bucket cylinder, link and lever the lift capacities will increase by 1,320 kg. Lifting capacity of the excavator is limited by machine stability and hydraulic capacity.

According to European Standard, EN 474-5: In the European Union excavators have to be equipped with an overload warning device, a load diagram and automatic safety check valves on hoist cylinders and stick cylinder(s), when they are used for lifting operations which require the use of lifting accessories.





# Dimensions Front Shovel

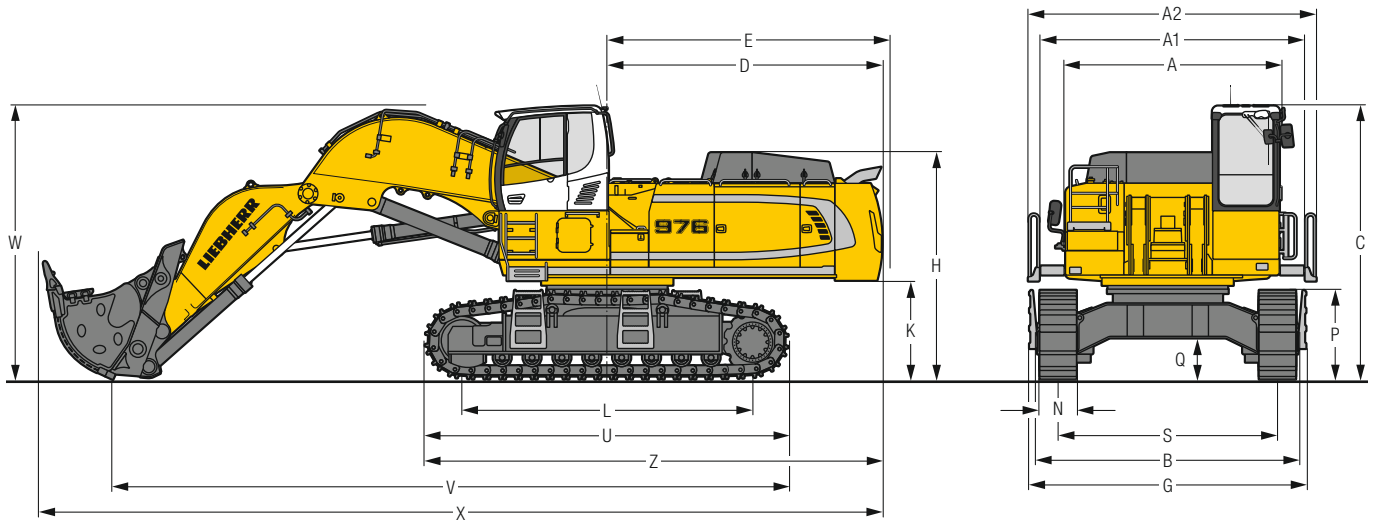

HD	mm
A	3,565
A1	4,355
A2	4,730
C	4,495/4,690*
D	4,515
E	4,640
H	3,725
K	1,620
L	4,770
P	1,460

HD	mm
Q	682
S	3,600
U	5,955
N	500 600 750
B	4,290 4,290 4,350
G	4,540 4,540 4,540
Z	7,490
V	11,100
W	4,500
X	13,850

\* with FOPS top guard

# Front Shovel

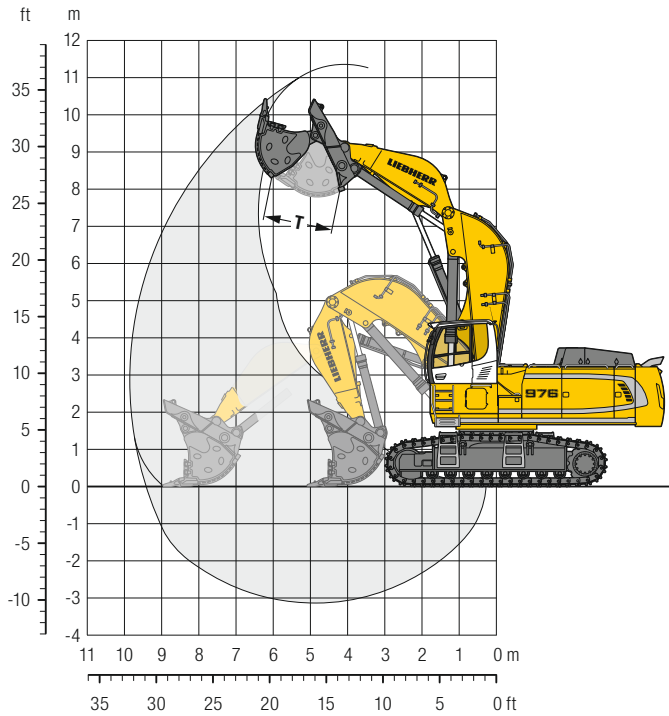

## Digging Envelope

Max. reach at ground level	m	9.40
Max. dumping height	m	7.80
Max. crowd length	m	3.90
Bucket opening width T	mm	1,825

## Forces

Max. crowd force	kN	690
Max. crowd force at ground level	kN	490
Max. breakout force	kN	500

## Operating Weight and Ground Pressure

The operating weight includes the basic machine with cab elevation 800 mm, shovel attachment and front shovel 5.10 m<sup>3</sup> (9,100 kg), level II.

Undercarriage		HD		
		500	600	750
Pad width	mm	500	600	750
Weight	kg	91,500	92,200	93,300
Ground pressure	kg/cm <sup>2</sup>	1.76	1.48	1.20

## Front Shovels

Cutting width	Capacity ISO 7451	Weight	Wear kit level	HD-Undercarriage	
				Shovel attachment	
mm	m <sup>3</sup>	kg		▲	■
2,700	5.10	8,450	I	▲	■
2,700	5.10	9,100	II	▲	■
2,700	5.10	10,150	III	▲	■
2,700	5.40	10,600	III	▲	■
2,700	5.60	8,750	I	▲	■
2,700	5.60	9,450	II	▲	■
2,700	5.60	10,600	III	▲	■
2,700	6.00	9,950	I	▲	■
2,700	6.00	10,700	II	▲	■

Level I: For non-abrasive materials, such as limestone without flint inclusion, shot material or easily breakable rock, i.e., deteriorated rock, soft limestone, shale, etc.

Level II: For pre-blasted heavy rock, or deteriorated, cracked material (classification 3 to 4, according to DIN 18300)

Level III: For highly-abrasive materials such as rock with a high silica content, sandstone etc.

Max. material weight ▲ = ≤ 2.0 t/m<sup>3</sup>, ■ = ≤ 1.8 t/m<sup>3</sup>, ▲ = ≤ 1.65 t/m<sup>3</sup>, ■ = ≤ 1.5 t/m<sup>3</sup>

# Dimensions and Weights

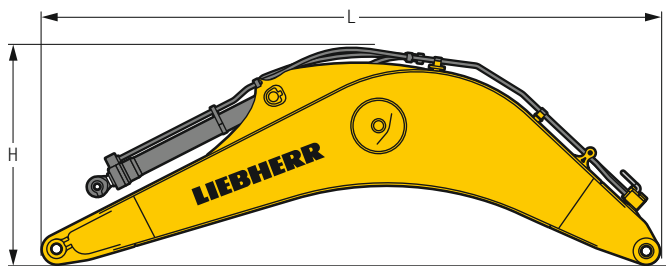
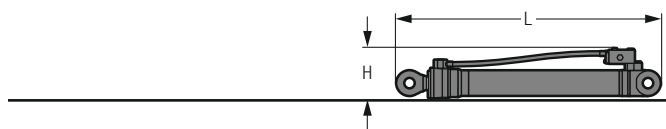
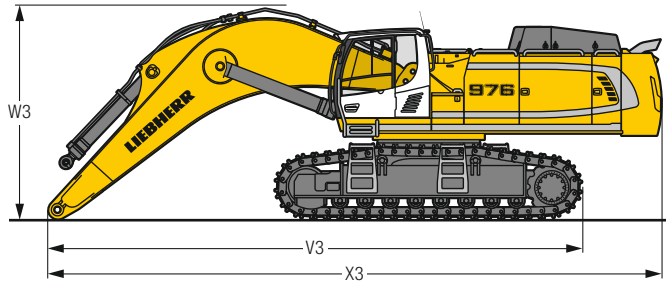
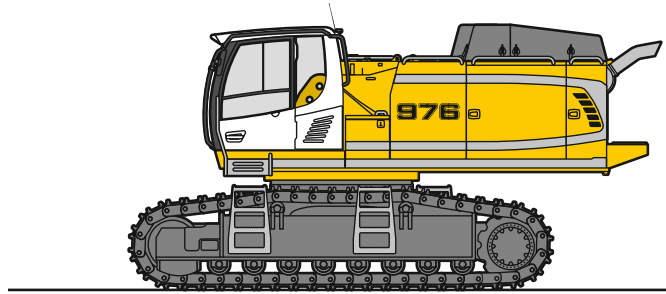

## Basic Machine

Track pads	mm	500	600	750
Weight with backhoe attachment and HD-undercarriage without counterweight	kg	51,050	51,800	52,900
Weight with shovel attachment and HD-undercarriage without counterweight	kg	51,150	51,900	53,000
Weight with backhoe attachment and LC-V-undercarriage without counterweight	kg	56,400	57,200	58,350

## Basic Machine

		HD	LC-V
V3 Mono boom 7.20 m	mm	10,350	10,400
Mono boom 8.60 m	mm	13,450	13,400
Mono boom 10.50 m	mm	13,650	13,800
W3 Mono boom 7.20 m	mm	4,150	4,250
Mono boom 8.60 m	mm	4,500	4,550
Mono boom 10.50 m	mm	4,900	5,000
X3 Mono boom 7.20 m	mm	11,950	11,900
Mono boom 8.60 m	mm	11,700	11,850
Mono boom 10.50 m	mm	15,450	15,400

## Cab Elevation

		800 mm
L Length	mm	1,890
H Height	mm	925
Width	mm	1,370
Weight	kg	600

## Counterweight

		Std	heavy
L Length	mm	775	775
H Height	mm	1,595	1,595
Width	mm	3,360	3,360
Weight	kg	14,100	16,000

## Upper Protection Screen

L Length	mm	1,960
H Height	mm	190
Width	mm	1,110
Weight	kg	75

## Hoist Cylinders (two)

L Length	mm	2,920
H Height	mm	550
Width	mm	400
Weight	kg	2 x 1,050

## Mono Boom with Stick Cylinder

Stick length	m	7.20	8.60	10.50
L Length	mm	7,550	8,950	10,850
H Height	mm	2,700	2,800	3,050
Width	mm	1,460	1,460	1,460
Weight	kg	9,500	10,400	11,500

# Dimensions and Weights

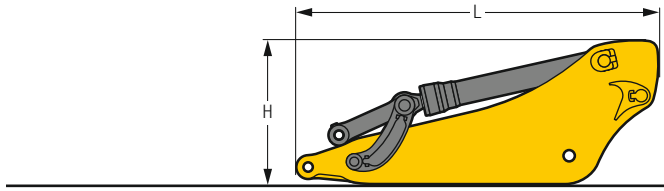

## Stick with Bucket Cylinder

Stick length	m	2.90	3.30	3.80	4.70	5.80
L Length	mm	4,050	4,450	4,900	5,800	6,900
H Height	mm	1,700	1,650	1,500	1,450	1,400
Width	mm	900	900	900	900	900
Weight	kg	4,450	4,600	4,800	5,150	5,100

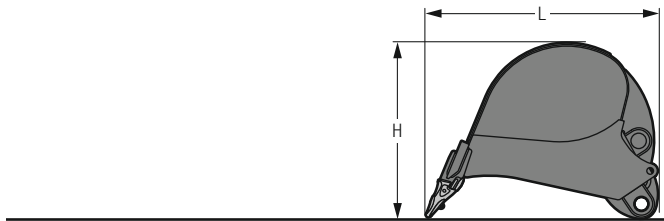

## Backhoe Buckets

					Std	
Cutting width	mm	1,250	1,400	1,600	1,800	1,950
Capacity	m <sup>3</sup>	2.20	2.60	3.10	3.60	4.10
L Length	mm	2,500	2,500	2,500	2,500	2,500
H Height	mm	1,900	1,900	1,900	1,900	1,900
Width	mm	1,300	1,450	1,650	1,850	2,000
Weight	kg	3,100	3,450	3,750	4,000	4,200

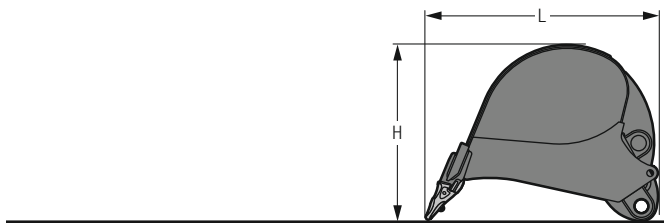

## Backhoe Buckets

					Std	
Cutting width	mm	2,150	2,150	2,300	2,300	2,450
Capacity	m <sup>3</sup>	4.60	5.20	5.60	6.20	6.60
L Length	mm	2,500	2,600	2,600	2,850	2,850
H Height	mm	1,900	1,950	1,950	2,050	2,050
Width	mm	2,200	2,350	2,350	2,350	2,650
Weight	kg	4,450	4,600	4,800	5,000	5,100

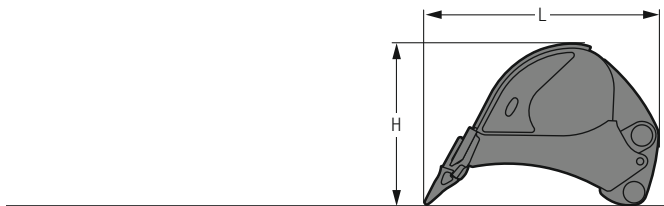

## Backhoe Buckets

					HD
Cutting width	mm	1,400	1,600	1,800	1,950
Capacity	m <sup>3</sup>	2.60	3.10	3.60	4.10
L Length	mm	2,450	2,450	2,450	2,450
H Height	mm	1,950	1,950	1,950	1,950
Width	mm	1,450	1,650	1,850	2,000
Weight	kg	3,800	4,250	4,400	4,800

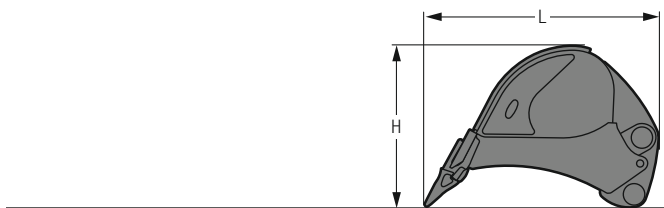

## Backhoe Buckets

					HD
Cutting width	mm	2,150	2,150	2,300	2,300
Capacity	m <sup>3</sup>	4.60	5.20	5.60	6.20
L Length	mm	2,450	2,450	2,550	2,850
H Height	mm	1,950	1,950	1,950	2,050
Width	mm	2,200	2,350	2,350	2,350
Weight	kg	5,050	5,400	5,450	5,900

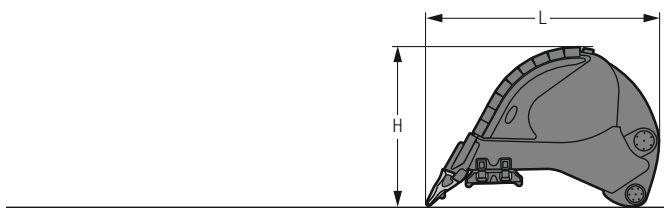

## Backhoe Buckets

					HDV
Cutting width	mm	1,950	2,150	2,150	2,300
Capacity	m <sup>3</sup>	4.20	4.70	5.20	5.70
L Length	mm	2,450	2,450	2,450	2,600
H Height	mm	1,950	1,950	1,950	1,950
Width	mm	2,000	2,200	2,350	2,350
Weight	kg	5,700	6,000	6,300	6,400

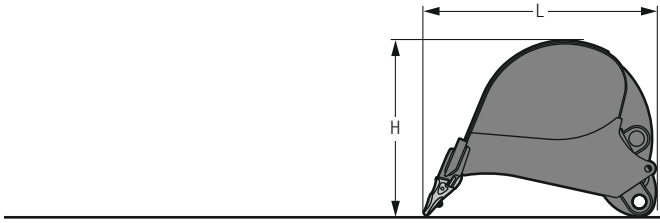

### Backhoe Buckets R 966

Std

Cutting width	mm	1,350	1,550	1,750	1,950	2,150
Capacity	m <sup>3</sup>	2.00	2.50	3.00	3.50	4.00
L Length	mm	2,400	2,400	2,400	2,400	2,400
H Height	mm	1,700	1,700	1,700	1,700	1,700
Width	mm	1,400	1,600	1,800	2,000	2,200
Weight	kg	2,750	2,950	3,150	3,450	3,600

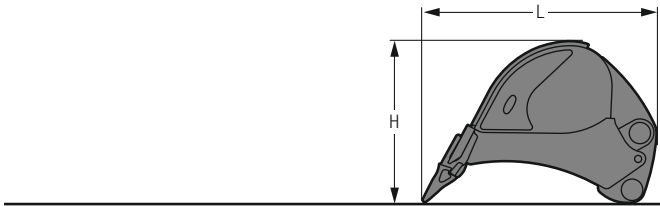

### Backhoe Buckets R 966

HD

Cutting width	mm	1,600	1,800	2,000	2,150
Capacity	m <sup>3</sup>	2.00	2.50	3.00	3.50
L Length	mm	2,300	2,300	2,300	2,350
H Height	mm	1,600	1,600	1,600	1,650
Width	mm	1,650	1,850	2,050	2,200
Weight	kg	3,550	3,850	4,100	4,450

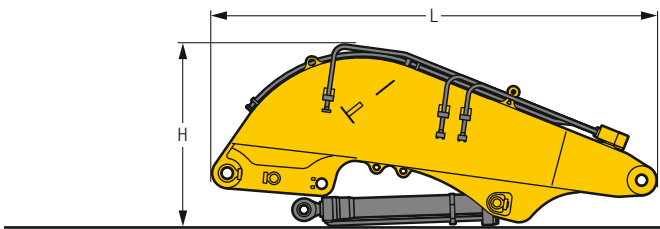

### Shovel Boom

L Length	mm	4,950
H Height	mm	2,050
Width	mm	1,650
Weight without crowd cylinder	kg	7,300
Weight crowd cylinder	kg	2 x 450

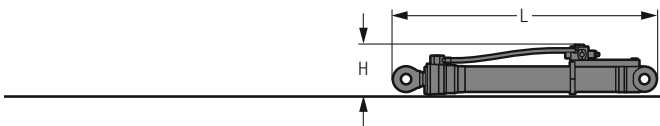

### Shovel Hoist Cylinders (two)

L Length	mm	2,920
H Height	mm	550
Width	mm	450
Weight	kg	2 x 1,100

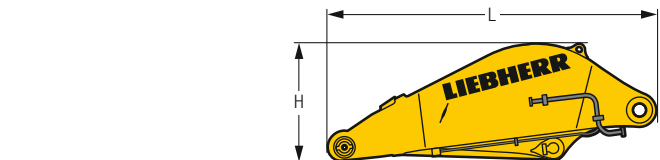

### Shovel Stick

L Length	mm	3,660
H Height	mm	1,300
Width	mm	1,800
Weight	kg	4,650

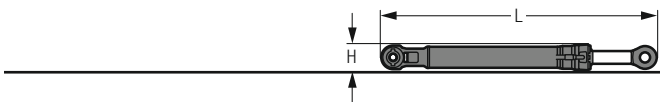

### Shovel Bucket Cylinders (two)

L Length	mm	3,050
H Height	mm	450
Width	mm	450
Weight	kg	2 x 625

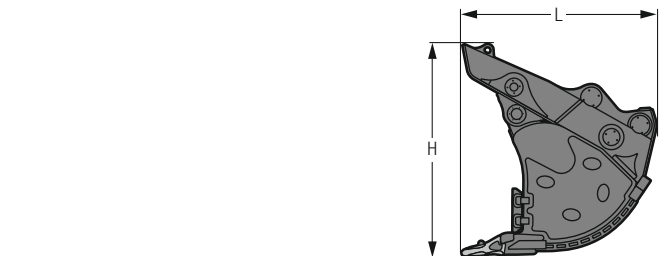

### Front Shovels

Cutting width	mm	2,700	2,700	2,700	2,700
Capacity	m <sup>3</sup>	5.10	5.40	5.60	6.00
L Length	mm	2,600	2,840	2,800	2,800
H Height	mm	2,700	2,840	2,700	2,800
Width	mm	2,700	2,700	2,700	2,700
Weight					
Level I	kg	8,450	–	8,750	9,950
Level II	kg	9,100	–	9,450	10,700
Level III	kg	10,150	10,600	10,600	–

# Standard Equipment

## Undercarriage

- Chain guide 3 pieces
- Lashing eyelets
- Sprocket double-toothed with dirt ejector
- Supporting rollers with double bearings
- Track pads, chamfered
- Track rollers, lifetime-lubricated
- Tracks, sealed and greased

## Uppercarriage

- Engine hood with two-part gas spring opening
- Fuel tank cap lockable with padlock
- Handrails
- Headlights on uppercarriage, front, halogen, 2 pieces
- Internal platform with access to engine and hydraulic compartments
- Manual main switch
- Sound insulation
- Storage space, lockable
- Swing brake lock, maintenance-free
- Tool set 29 pieces
- Walkway, both-sided

## Hydraulic System

- Dedicated swing circuit
- Filter with integrated fine filter area
- Liebherr hydraulic oil
- Positive Control system
- Pressure storage for controlled lowering of equipment with engine turned off
- Pressure test ports for hydraulic
- Shut-off valve between hydraulic tank and pumps
- Work mode selector

## Engine

- Common-Rail injection system
- Conform with stage IV emission standard
- Engine idling, automatic, sensor-controlled
- Fixed geometry turbo charger
- Fuel filter and water separator
- Intercooler
- Liebherr SCR technology
- Stepless adjustable engine speed

## Operator's Cab

- 2" seat belt with retractor
- 7" colour multifunction display with touchscreen
- Air conditioning, automatic
- Camera for side area monitoring
- Cigarette lighter and ashtray
- Coat hook
- Cup holder
- Engine oil level monitoring on touchscreen
- Fuel consumption indicator on touchscreen
- Headlights on cab, front, halogen, 2 pieces
- Hydraulic suspension
- Impact-resistant roof window
- Impact-resistant two-piece windshield
- Interior light
- LiDAT Plus (Liebherr data transfer system) \*
- Mechanical hour meters, readable from outside the cab
- Operator seat Comfort with longitudinal and vertical damping
- Radio pre-installation
- Rain hood over front window opening
- Rearview mirrors
- Rear view monitoring camera
- Rear window emergency exit
- Roll-down sun blinds
- Rubber floor mat
- Sliding windows in cab door
- Storage bin
- Storage space
- Tinted windows
- Urea tank level monitoring on touchscreen
- Wiper / washer

## Attachment

- Boom cylinders oil regeneration
- Headlights on boom, halogen, 2 pieces, protections included
- Liebherr central lubrication system, fully-automatic (except connecting link for bucket kinematics)
- Load valve for stick cylinder (on distributor)
- Pipe fracture safety valves for boom and stick cylinders
- Stick cylinder oil regeneration

Non-exhaustive list, please contact us for further information.

\* optionally extendable after one year

# Options

## Undercarriage

- Chain guide 4 pieces
- Chain guide full length
- Protection plate for wrecking ball operation
- Reinforced cover and base plate for undercarriage centre section
- Special painting
- Travel drive protection
- Travel gear support, reinforced

## Uppercarriage

- Automatic tiltable access ladder
- Cab elevation
- Counterweight 16.0 t
- Electric socket for external start-up aid (24 V)
- Electric socket for urea filling station (24 V)
- Engine compartment lighting
- Fine filter protection grid for radiator
- Fuel tank refilling pump
- Lubrication line protection (swing ring)
- Protection for headlights on uppercarriage
- Reversible fan drive
- Special painting
- Storage space with extended tool set 40 pieces (incl. tool box)
- Swing drive protection
- Walkway, wide version with guard rail
- Wiggins quick coupling for fuel

## Hydraulic System

- Bypass filter for hydraulic oil
- Liebherr hydraulic oil, adapted for extreme climate conditions
- Liebherr hydraulic oil, biodegradable
- Preheating for hydraulic oil (240 V)

## Engine

- Air pre-filter with dust trap
- Automatic engine shut-down after idling (without timer)
- Engine shut-down self-timer
- Preheating for fuel, coolant and engine oil (240 V)
- Wiggins quick coupling for engine oil

## Operator's Cab

- 4-points seat belt
- Acoustic travel alarm deactivatable
- Additional headlights cab, front and/or rear, halogen or LED, 2 pieces
- Adjustable intensity headlights (LED)
- Amber beacon on cabin, halogen, 1 piece
- Auxiliary heater programmable
- Bottom windscreen wiper
- Cool box (12 V)
- Electronic anti-theft device
- Emergency stop in cab
- FGPS front guard
- Fire extinguisher
- First-aid box
- Follow me home headlights
- Footrest
- FOPS top guard
- Handrests elevated for joysticks
- Headlights on cab, front, LED, 2 pieces
- Liebherr proportional control
- Lighting for cabin access
- Operator seat Comfort
- Operator seat Premium
- Radio Comfort
- Roof window wiper
- Skyview 360°
- Special painting
- Sun visor
- Switchable high-pressure control

## Attachment

- Boom bottom protection
- Bucket cylinder rod protection
- Cylinders check valve
- Filter for hydraulic hammer return flow
- Headlights on boom, LED, 2 pieces
- High pressure circuit
- Hoist cylinder stroke limitation, adjustable
- Leak oil line for attachment
- Liebherr automatic lubrication system for connecting link
- Liebherr bucket range
- Liebherr quick coupler, hydraulic or mechanical
- Liebherr tooth system
- Lifting eye on boom and stick
- Load holding valve for bucket cylinder
- Medium pressure circuit
- Overload warning system
- Protection for hoist cylinders hoses
- Security for hoist cylinders
- Special painting
- Stick bottom protection
- Stick cylinder rod protection
- Stick cylinder stroke limitation, adjustable
- Sticks, sealed version
- Tool Control, 10 tool adjustments selectable over the display

Non-exhaustive list, please contact us for further information.

Options and/or special attachments, supplied by vendors other than Liebherr, are only to be installed with the knowledge and approval of Liebherr in order to retain warranty.

# The Liebherr Group of Companies



## Wide Product Range

The Liebherr Group is one of the largest construction equipment manufacturers in the world. Liebherr's high-value products and services enjoy a high reputation in many other fields. The wide range includes domestic appliances, aerospace and transportation systems, machine tools and maritime cranes.

## Exceptional Customer Benefit

Every product line provides a complete range of models in many different versions. With both their technical excellence and acknowledged quality, Liebherr products offer a maximum of customer benefits in practical applications.

## State-of-the-art Technology

To provide consistent, top quality products, Liebherr attaches great importance to each product area, its components and core technologies. Important modules and components are developed and manufactured in-house, for instance the entire drive and control technology for construction equipment.

## Worldwide and Independent

Hans Liebherr founded the Liebherr family company in 1949. Since then, the family business has steadily grown to a group of more than 130 companies with nearly 44,000 employees located on all continents. The corporate headquarters of the Group is Liebherr-International AG in Bulle, Switzerland. The Liebherr family is the sole owner of the company.

[www.liebherr.com](http://www.liebherr.com)

## Liebherr-France SAS

2 avenue Joseph Rey, B.P. 90287, FR-68005 Colmar Cedex  
☎ +33 389 21 30 30, Fax +33 389 21 37 93  
[www.liebherr.com](http://www.liebherr.com), E-Mail: [info.lfr@liebherr.com](mailto:info.lfr@liebherr.com)  
[www.facebook.com/LiebherrConstruction](https://www.facebook.com/LiebherrConstruction)